

# Just E3 Plug&play Kit Manual Test LiFePO4



- |                                     |                                       |
|-------------------------------------|---------------------------------------|
| <b>EN</b> Installation Instructions | <b>IT</b> Istruzioni di montaggio     |
| <b>DE</b> Montageanleitung          | <b>LT</b> Montavimo Instrukcijos      |
| <b>CZ</b> Montážní návod            | <b>LV</b> Instalācijas instrukcija    |
| <b>DK</b> Monteringsvejledning      | <b>NO</b> Monteringsanvisning         |
| <b>EE</b> Paigaldusjuhend           | <b>PL</b> Instrukcja montażu          |
| <b>FI</b> Asennusohje               | <b>SE</b> Installationsanvisning      |
| <b>FR</b> Notice de montage         | <b>RU</b> Инструкция по монтажу       |
| <b>HU</b> Szerelési útmutató        | <b>SRB</b> Instrukcija za instalaciju |
| <b>HR</b> Uputstvo za montažu       | <b>SK</b> Montážny návod              |
| <b>NL</b> Montagehandleiding        | <b>SLO</b> Navodilo za montažo        |
| <b>RO</b> Instructuni de montaj     | <b>CN</b> 安装说明书                       |



1. Installation and commissioning may only be carried out by authorized specialists and wired in accordance with the latest IEE electrical regulations or the national standards.
2. Mains power must be switched off before carrying out installation.
3. The manufacturer, shall not be liable for any damage resulting from inappropriate modifications to the luminaire or faulty installation.
4. Light source can't be replaced.  
The control gear provides basic insulation between the LV supply and the control circuit.



SAP Code	Product Description	Input	Wattage	Operation Temperature
96635766	JUST E3 PLUG&PLAY KIT MANUALTEST LIFEPO4	AC 220-240V 50-60Hz	3W	0-+50°C

YH25

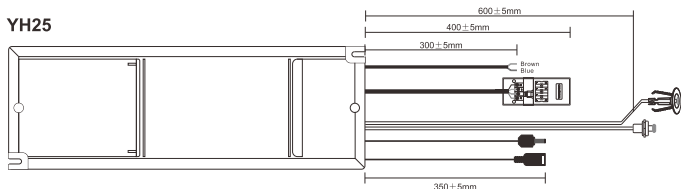

**1**

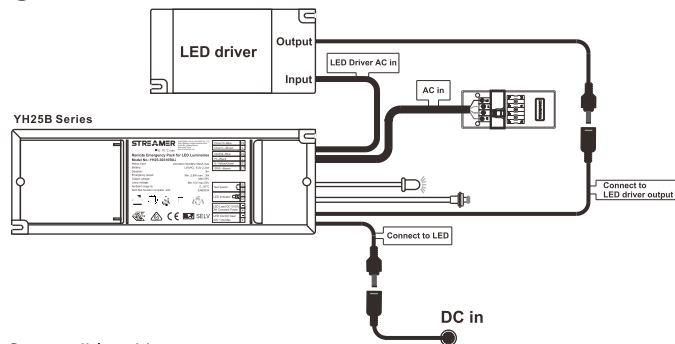

Compatible with



Anna Vario

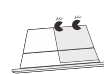

Amy Vario



Zoe Vario



Lily

**2**

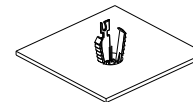

Make a 20mm cutting hole

**3**

L1: Unswitched Line N : Neutral  
L : Switched Line

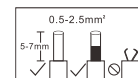
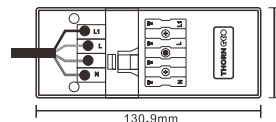

**4** A. Connect the battery

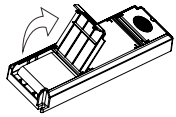

1. Open the battery hatch

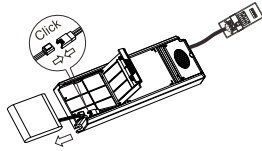

2. Connect the battery plug

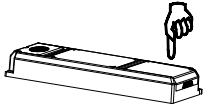

3. Close the hatch

**B. Mark installation date**

Please indicate the date of installation on this label.

High Temp. LFP Battery  
Installation date:

1	2	3	4	5	6	7	8	9	10	11	12
2022	2023	2024	2025	2026	2027	2028					

LFP

Notes: If users would like to change the batteries pack, please use the nominated models of STREAMER, then it will be under the warranty.

**5** Fill in 4-digit code on back of the product

		1		A		180
X	Self-contained	0	Non-Maintained	A	Including test device (Manual Test)	180 Duration (Minutes)
		1	Maintained	F	Self-test according to IEC 61347-2-7, EL-T marked	

**6** A. Replace the battery ( Order 59011337 )

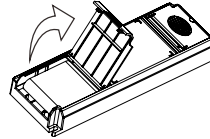

1. Open the battery hatch

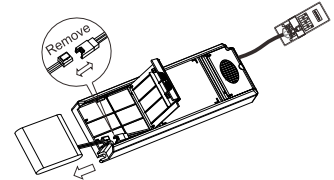

2. Remove the battery and disconnect the plug

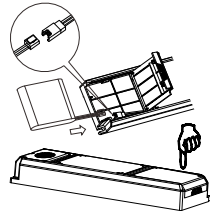

3. Put the battery in the battery box and close it

**B. Mark installation date**

Please indicate the date of installation on this label.

High Temp. LFP Battery  
Installation date:

1	2	3	4	5	6	7	8	9	10	11	12
2022	2023	2024	2025	2026	2027	2028					

LFP

Notes: If users would like to change the batteries pack, please use the nominated models of STREAMER, then it will be under the warranty.

**Explanation of LED indicator**

	Color	LED indication	Status	Comment
	Green	Permanent green	Charging Mode Fully Charged	AC mode
		Green and red off	DC mode	Battery operation (emergency mode)

